



Rugged Pleat Control Panel

RP and RPH Control Panel

Installation and Operation Manual

Installation, Operation, and Service Information

Reference Installation and Operation Manual - IOM AG8658001 and
Replacement Parts List - RPL AG8658101



This manual contains specific precautions related to worker safety. The hazard alert image denotes safety related instructions and warnings in this manual. DO NOT install, operate, or perform maintenance on this collector until you have read and understood the instructions, precautions and warnings contained within this manual.

English
Master Language

IOM AG8732701 (ENG)
Revision 0

IMPORTANT NOTES

This manual has been supplied to assist with the installation, operation and maintenance for the dust collector accessory purchased. Please read the manual before installing, operating, or performing maintenance on the accessory as it contains specific precautions for worker safety. It is the owner's responsibility to ensure that this manual is available for use by installers, operators and maintenance personnel that will be working with this dust collector accessory. This manual is the property of the owner and should be left with the collector when the accessory installation has been completed. **DO NOT** operate the collector until you have read and understood the instructions and warnings located in the installation and operation manual.

For additional copies of this manual, contact Donaldson Torit



The Safety Alert Symbol indicates a hazardous situation which, if not avoided could result in death or serious injury. Obey all safety messages following this symbol to avoid possible injury or death. The possible hazards are explained in the associated text messages.

NOTICE

NOTICE indicates a potential situation or practice which is not expected to result in personal injury, but which if not avoided, may result in damage to equipment.

Contents

- IMPORTANT NOTES i
- 1 Safety Communication 1
- 2 Product Description 3
- 3 HMI Operation 6
 - Home Screen 7
 - Trends 10
 - Alarms 11
 - HMI Login 12
 - HMI Security 13
 - Remote Access WebGUI 14
 - Setpoints 15
 - Cleaning 15
 - Airflow 17
 - Airlock 18
 - Motor Timers 19
 - Defaults 20
 - Maintenance 21
 - Motors 21
 - Pulse Cleaning Display 22
 - Pressure Sensors 23
 - Time and Date 24
 - Configuration 25
 - Motors 25
 - Aux Motors 26
 - Aux Alarms 27
 - Spokes 28
 - HMI 29
 - Diagnostics 30
 - Digital Inputs 30
 - Digital Outputs 31
 - Analog Inputs 32
 - Hardware Status 33
 - Software Status 34
 - Modes of Operation 35
 - Auto Mode 35
 - Troubleshooting 37
- Appendix A - Installation 39
 - Electrical Wiring 41
 - Solenoid Connection 42
 - Start-up / Commissioning 44
 - Decommissioning 45
- Appendix B - Quick Start Procedure 46
 - Product Information 49
 - Service Notes 50
- Donaldson Industrial Air Filtration Warranty 52

1 Safety Communication



Improper operation of dust collectors and/or dust control systems may contribute to conditions in a work area or facility which could result in severe personal injury, and product or property damage. All dust collection equipment should be used only for its intended purpose and should be properly selected and sized for its intended use.

Process owners have important responsibilities relating to identifying and addressing potential hazards in their processes. When the potential for handling combustible dust exists within a process the process owner should include combustion hazards in their risk management activities and should comply with applicable codes and standards related to combustible dust.

Electrical installation must be performed by a qualified electrician.

This equipment is not designed to support site ducts, piping, or electrical services. All ducts, piping, or electrical services must be adequately supported to prevent injury and/or property damage.

Site selection must account for wind, seismic zone, and other load conditions.

Equipment may reach peak sound pressure levels above 80 dB (A). Noise levels should be considered when selecting collector location.

Most dusts present safety and health hazards that require precautions. Wear eye, respiratory, head and other protection equipment suitable for the type of dust.

Some components may be heavier than they appear. Use appropriate lifting methods to avoid personal injury and/or property damage.

Combustible Dust Hazards

Among other considerations, the current NFPA standards require owners whose processes involve potentially combustible materials to have a current Dust Hazard Analysis, which can serve as the foundation for their process hazard mitigation strategy. Mitigation may include but is not limited to:

- Prevention of all ignition sources from entering any dust collection equipment.
- Selection and implementation of fire and explosion mitigation, suppression, and isolation strategies appropriate for the risks in their process.
- Development and use of work practices to maintain safe operating conditions, and to ensure combustible dust does not accumulate within their plant or process equipment.

Donaldson designs, manufactures, and sells industrial air filtration products for a wide variety of applications. Some applications may include processes or materials with inherent fire and explosion hazards. Donaldson is neither an expert nor a certified consultant in fire, spark, or explosion detection, suppression, or control. Donaldson does not provide engineering consulting services related to process or dust hazard analyses, or code and standard compliance. Complying with applicable codes and standards and managing the risks associated with the process or materials remains the responsibility of the process owner/operator. Donaldson may provide referrals to consultants, suppliers of equipment or services related to the detection and/or mitigation of sparks, fires and/or explosions, but Donaldson does not assume responsibility for any such referrals, nor does Donaldson assume any liability for the fitness of a mitigation strategy or product for a particular installation or application. The process owner's final selection of dust collectors and risk mitigation strategies should be based on the outcome of a Dust Hazard / Process Hazard Analysis performed by the process owner. Although early engagement of a dust collector supplier provides helpful insights on the availability and features of various products, process owners should consult with a combustible dust expert and/or a process safety expert before making actual product and mitigation strategy selections.

Donaldson recommends that all industrial air filtration system designs be reviewed and approved by an expert consultant who is responsible for the integrity of the system design and compliance with applicable codes and standards. It is the process owner's responsibility to understand the risks in their process and mitigate those risks in accordance with all applicable laws, regulations and standards, including those published by the NFPA. Donaldson also recommends that proper maintenance and housekeeping procedures and work practices be evaluated, developed, and followed to maintain any industrial air filtration products in safe operating condition.

Many factors beyond the control of Donaldson can affect the use and performance of Donaldson products in a particular application, including the conditions under which the product is used. Since these factors are uniquely within the user's knowledge and control, it is essential the user evaluate the Donaldson products to determine whether the product is fit for the particular purpose and suitable for the user's application. All products, product specifications, and data (airflow, capacity, dimensions, or availability) are subject to change without notice, and may vary by region or country.

2 Product Description

The Rugged Pleat (RP) Control Panel and Controllers are a control system for the RP Collector that starts, monitors and shuts down the electrical motors used in conjunction with the RP collector.

RP Control Panel

The RP Control Panel provides the system logic to start and stop motors in the proper sequence and provides the following:

- Motor starters and logic to start and stop all configured motors in the appropriate order and timing. This includes system fan motor, PD pump motor, cleaning arm drive motor, rotary airlock motor and others as requested
- HMI touchscreen home screen that provides at-a-glance collector operation monitoring
- PLC that operates the Perfect Pulse Cleaning System

RP Controller

For customers that have a central control room and their own motor starters, the RP Controller provides the system logic to send signals to motor starters for proper start-up and shut-down sequencing and the following:

- Logic to send start and stop signals to customer supplied motor starters in the appropriate order and timing. This includes system fan motor, PD pump motor, cleaning arm drive motor, rotary airlock motor and others as requested.
- HMI touchscreen home screen that provides at-a-glance collector operation monitoring
- PLC that operates the Perfect Pulse Cleaning System

If an RP Control Panel or RP Controller is not ordered with the RP Collector, the Perfect Pulse PLC will be installed in a NEMA 4 enclosure. If an RP Control Panel or Controller is ordered for the RP Collector, the Perfect Pulse PLC will be installed inside the RP Control Panel or Controller.

Standard Equipment

HMI Interface

A touchscreen interface located on the control panel allowing full control of the system from a graphical user interface and monitoring of the RP Collector.

PLC

Programmable Logic Controller which controls the sequencing of motors and pulsing.

VFD

Motor controller which can adjust the speed of the motor by modulating the frequency of AC power to the windings.

Setpoint

Desired value PLC will try to attain.

GL.iNet

WiFi VPN Router remote support device located inside control panel.

RP Collector

A continuous duty dust collector with pleated filters designed to handle applications with heavy dust loads. For complete information, see the most current version of the RP Installation, Operation, and Maintenance manual.

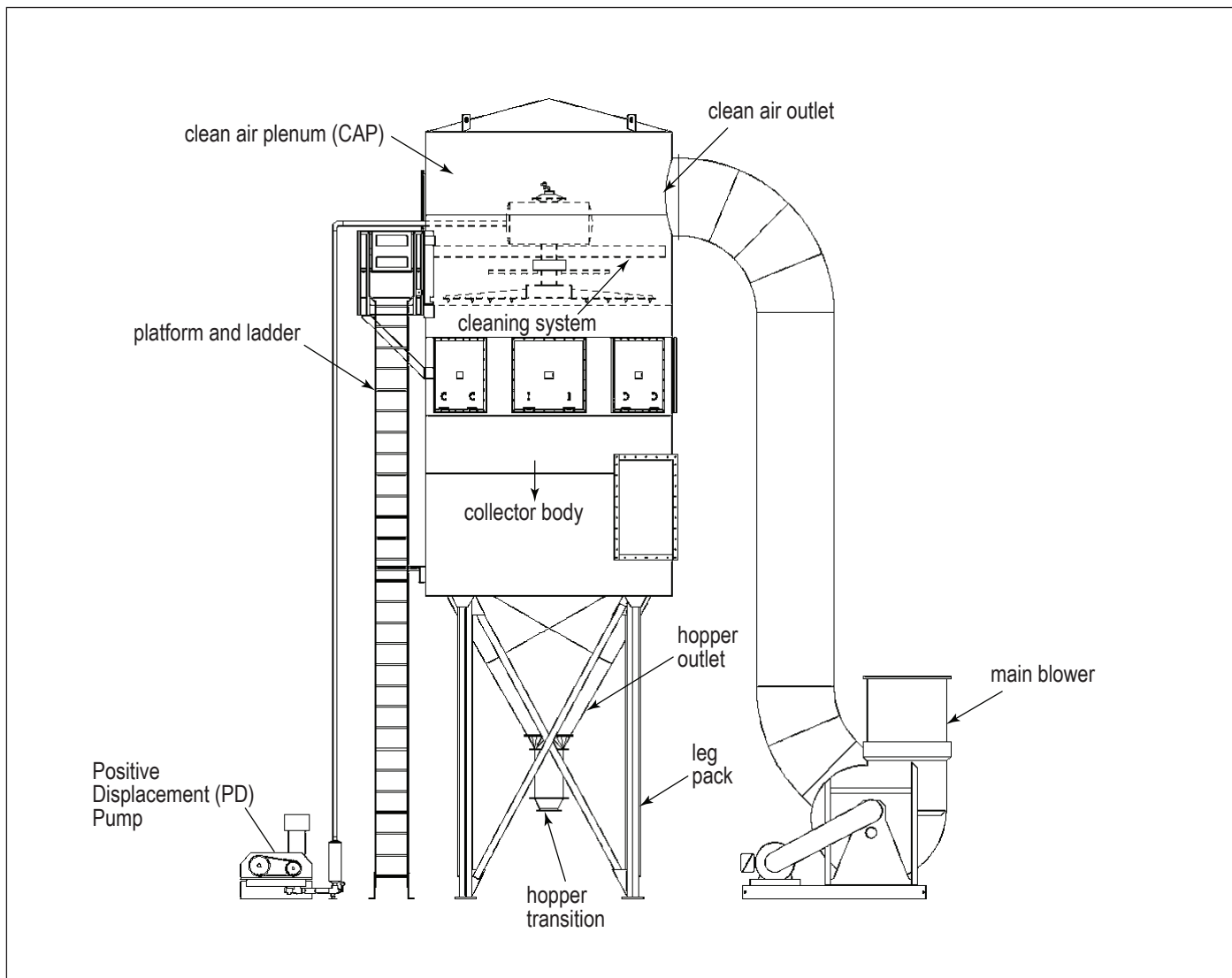

RP Control Panel

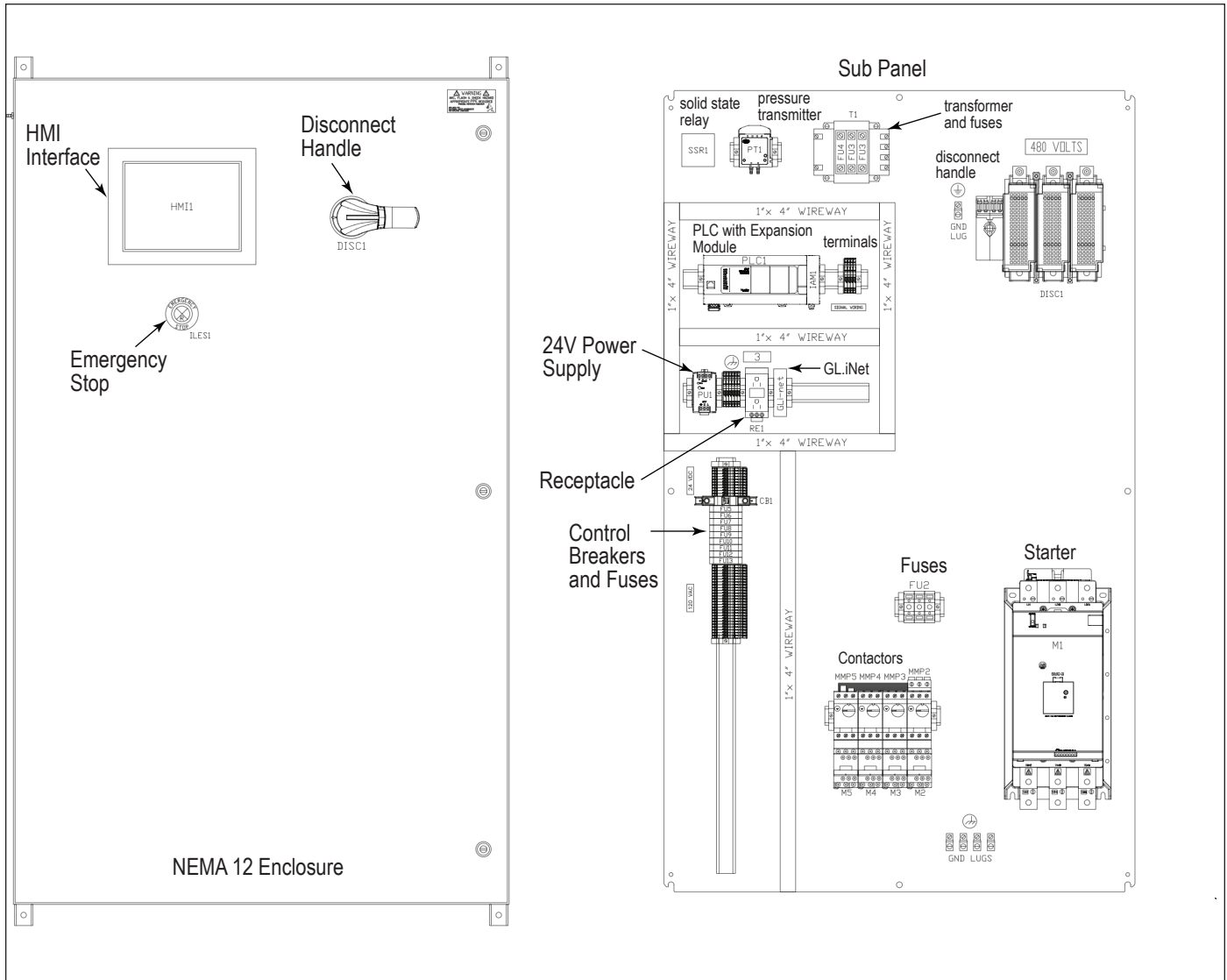

3 HMI Operation



Electrical work during installation, service or maintenance must be performed by a qualified electrician and comply with all applicable national and local codes.

Turn all power off and lock out all power before performing service or maintenance work.

Check that the collector is clear and free of all debris before starting.

Do not install in classified hazardous atmospheres without an enclosure rated for the application.

The Rugged Pleat HMI/PLC system when first booted will show a Splash screen which displays the Donaldson logo and a current version number. The user can touch anywhere on the screen to begin.



Home Screen

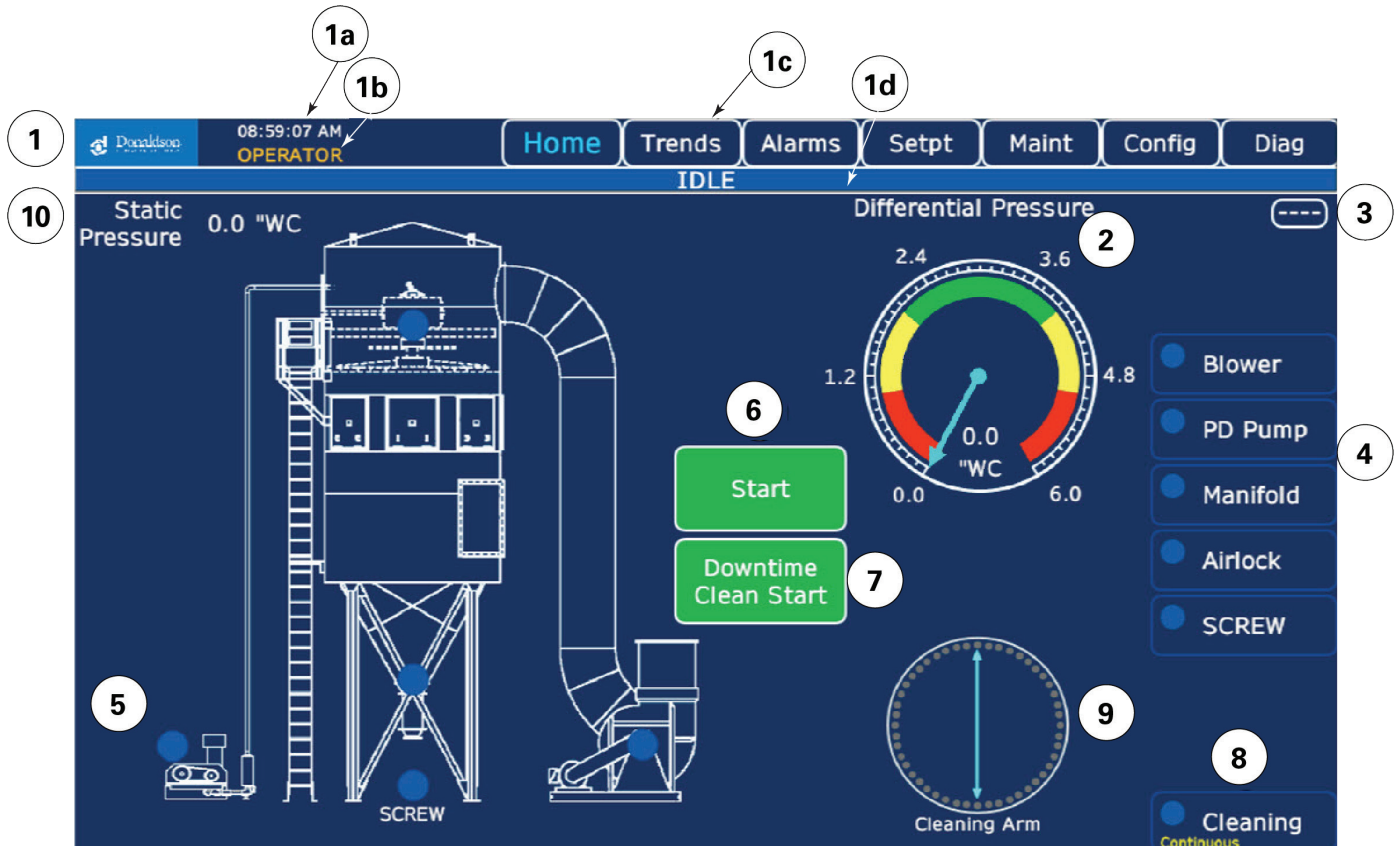

The **Home screen** is where overall system control will take place.

1. **Screen Header** is displayed on all screens showing the status of the system and allowing for navigation.
 - a. Current time
 - b. Shows elevated security, Username, blank if not logged in.
 - c. Navigation tabs. Blue text indicates what screen is currently being displayed.
 - i. Home Tab returns to home screen.
 - ii. Trends Tab displays Differential and Static pressure trends
 - iii. Alarms Tab shows red with active alarm. Brings you to Active and Historical alarms
 - iv. If user has improper credentials for Setpt, Maint, or Config screens, a login window will open.
 - d. System Status indicator values
2. **Differential Pressure Bar Graph** give quick indication of pressure level and limits.

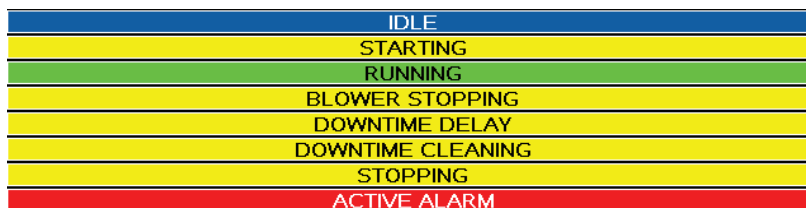

3. **Bar Graph / Gauge** selection allows user to toggle display based on preference.

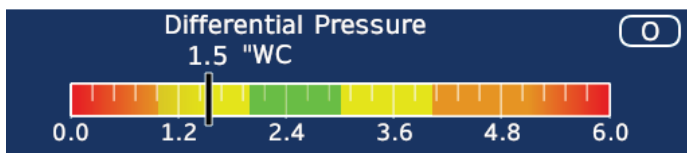

4. **Configured Motors** are displayed along the right side of the screen (referred to as Flags). Inset circles indicate motor status. Disabled alarms will be indicated by a yellow triangle. Touching the warning triangle will open a popup.

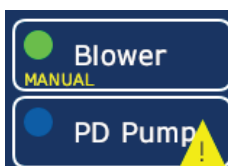

Proper credentials, indicated by a white border around the box, enable navigation to the Maintenance page of the selected motor.

5. **Motor Status Circles** are also located on the graphic to show approximate physical locations.

- a. (Solid) Idle
- b. (Blink) Starting
- c. (Solid) Running
- d. (Blink) Stopping
- e. (Solid) Alarm



6. The **START**  button will start the system in a sequenced order based on configured set points.

Once started, the **STOP**  button will be displayed to allow for a sequenced shutdown.

7. If the system is in an idle state, the **DT CLEAN START**  button can be used to start a downtime clean.

8. When the system is in cleaning mode the **CLEANING**  bar will indicate with a green light and the

9. **CLEANING ARM** will animate. Center line rotates to indicate cleaning arm rotation. Inner circles change color to indicate position has been pulsed, grey for no pulse, yellow for first, and green for second. If system is in Downtime Cleaning Mode, Time Remaining in the clean will be visible.

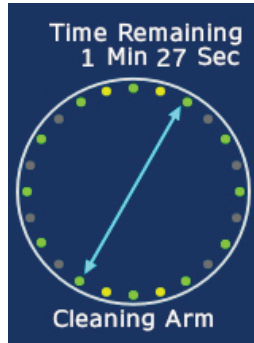

10. If the system blower is configured with a VFD the **Static Pressure** will be displayed in the upper left side of the screen. Current Value, 'Overrange' and 'Underrange' indications will be displayed.



Trends

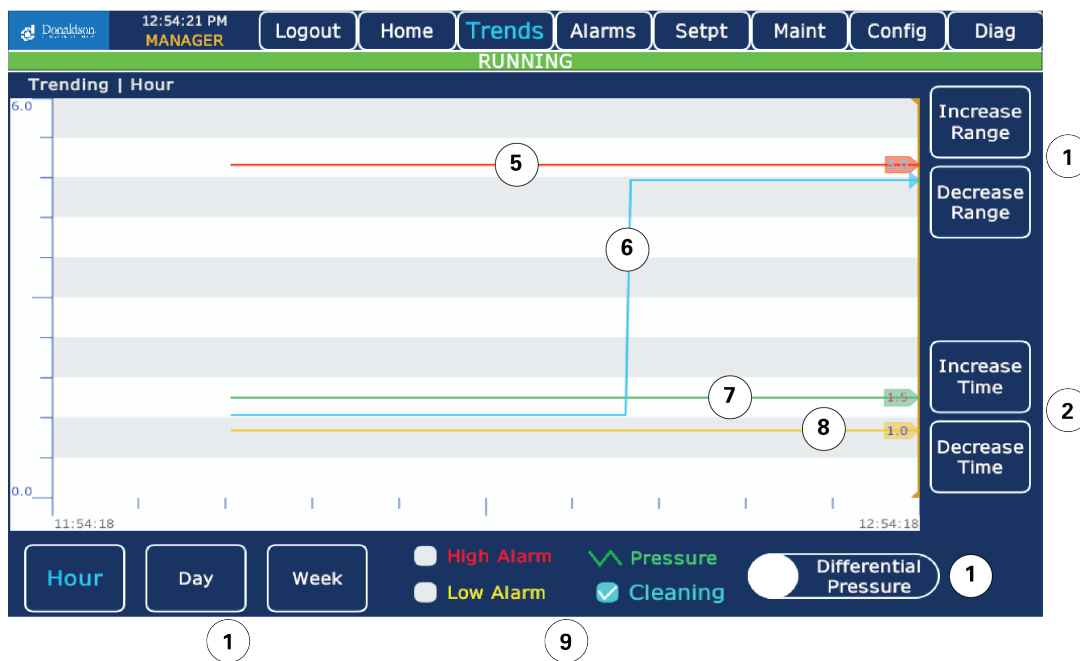

1. **Trend Value Range Selector** allows user to increase or decrease the range displayed on the trend. The default range is 0 - 5" WC. Pressing Increase will increase the range by 1 "WC. Pressing Decrease will decrease the range by 1 "WC.
2. **Trend Time Selector** allows the user to increase or decrease the time span of the trend. Pressing Increase will increase the start time by one unit thereby shortening the time span. Pressing Decrease will decrease the start time by one unit, lengthening the time span.
3. **Sample Selection Tabs** allow user to select a trend based on a sample rate and time span to be displayed.
 - f. The **Hour** tab will give a 60 minute span with a 20 second sample rate.
 - g. The **Day** tab will give a 24 hour span with a 600 second sample rate.
 - h. The **Week** tab gives a 7 day span with a 3600 second sample rate.
4. **Trend Selector** button will appear only if the blower is configured as a VFD, allowing selection of the static pressure trend.
5. **High Alarm** value shows on trend for reference.
6. **System Cleaning** indication for reference.
7. **Actual Pressure** value trend.
8. **Low Alarm** value shows on trend for reference.
9. **Trend Legend** indicates colors for trend pens and indicates alarms and cleaning. The box will be checked when the condition is true.

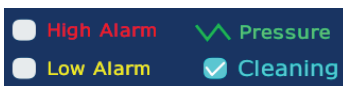

Alarms

The screenshot displays the 'Alarms' section of a control interface. At the top, there is a navigation bar with buttons for 'Logout', 'Home', 'Trends', 'Alarms' (highlighted), 'Setpt', 'Maint', 'Config', and 'Diag'. Below this, the page title is 'Alarms | Active'. A table lists active alarms with columns for 'Active Date', 'Active Time', 'AlarmStatus', and 'AlarmMessage'. One alarm is shown: 'TOP GATE FAILED TO CLOSE' on '12/21/2021' at '13:25:37' with status 'Active'. Below the table is an 'Aux Legend' table with columns for 'Aux Alarm 1', 'EMERGENCY STOP', 'Aux Motor 1', and 'SCREW'. To the left of the legend is a toggle switch labeled 'Active Alarms'. To the right are two red buttons: 'Silence' and 'Acknowledge Alarms'. Circled numbers 1 through 6 point to specific elements: 1 points to the alarm message, 2 to the active date/time, 3 to the toggle switch, 4 to the Aux Legend table, 5 to the Silence button, and 6 to the Acknowledge Alarms button.

Active Date	Active Time	AlarmStatus	AlarmMessage
12/21/2021	13:25:37	Active	TOP GATE FAILED TO CLOSE

Aux Legend			
Aux Alarm 1	EMERGENCY STOP	Aux Motor 1	SCREW

1. **Alarm Message** indicates what condition has triggered the alarm.
2. **Active Date/Time** shows when the alarm became active.
3. **Switch** allows user to switch between Active and Historical Alarms.
4. **Aux Alarm** and Motor Legend
5. **Silence** will silence the alarm horn.
6. **Acknowledge** will acknowledge the alarm. If the condition has cleared, the alarm is removed from the list.

HMI Login

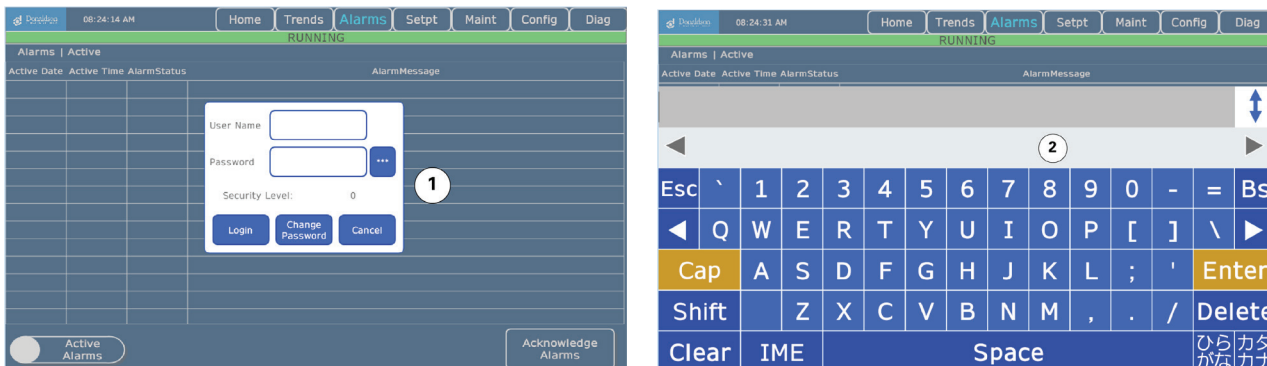

1. **Name/Password Entry** allows user to enter a Username and Password.
2. **Popup Keyboard** allows entry of Username & Password.
3. **Successful login** will enable restricted pages such as Setpt, Maint, and Config. The border around the Motor Names and Circles will turn white indicating that they are buttons to bring you to the Maintenance screen for that motor.

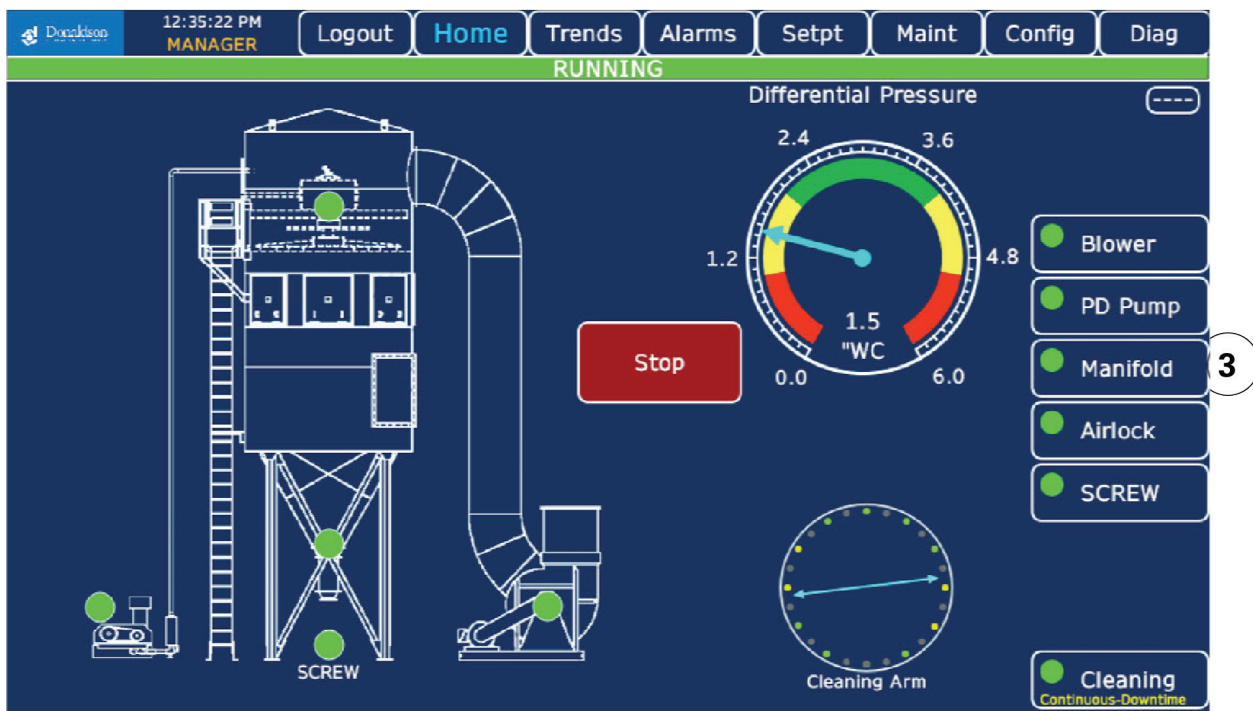

HMI Security

Many touch operations on the HMI are restricted by user security level. The login screen will automatically appear when a restricted access page is selected and the user will be prompted for the proper level of security credentials to gain access.

- There are four levels of security. If a touch item requires a higher level of security than is currently logged in, a popup window will appear and the user will be prompted for the proper credentials.
- Successful login will enable access to restricted pages such as Setpt, Maint, and Config. The border around the Motor Names and Circles will turn white indicating that they are buttons to bring you to the Maintenance screen for that motor.
- Current User is displayed in the top banner. If a user with elevated security is logged in, the Logout button will be shown to allow user to return to the OPERATOR level.
- If no activity is detected while security level is elevated, the system will return user to OPERATOR level after 15 minutes. The system will also return to the Home screen at this time.

Users

Enter username and password for required security level.

Security Level	Username	Password	Screens Allowed
0	OPERATOR	OPERATOR	Home, Trends, Alarms, Diag
1	MAINT		Home, Trends, Alarms, Setpt, Maint, Diag.
2	MANAGER		Home, Trends, Alarms, Setpt, Maint, Config (limited), Diag
3	CACO		All Options

The screenshot shows the top banner of the HMI interface. On the left, there is the Donaldson logo. Next to it, the time is 03:11:51 PM and the user is identified as MANAGER. A series of buttons are displayed: Logout, Home (highlighted in blue), Trends, Alarms, Setpt, Maint, Config, and Diag. Below these buttons, the status 'IDLE' is shown in white text on a dark blue background.

Remote Access WebGUI

WebGUI provides the ability to watch or operate the HMI screen remotely and can be launched from any web browser on the network.

1. Connect your device to the control network using the GL.iNet support device WiFi DCI_DUST with password Support!
2. Open a browser on your device. Supported browsers include
 - Safari iOS13 / iPad OS13 or later
 - Chrome iOS13 / iPad OS13 or later
 - Chrome Android or Windows
 - Edge (80.0.361.56 or later) Windows
3. Navigate to <http://192.168.31.12:8082/webgui/index.html>
The following screen will open.

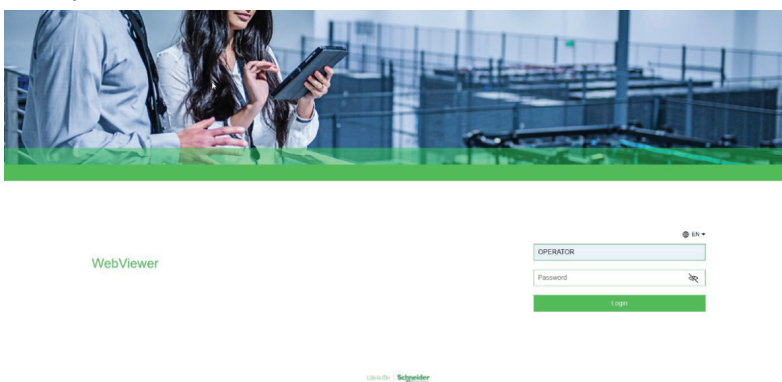

4. Log in with OPERATOR /OPERATOR.
5. Configure for your device and preferences using the Toolbar at the top of the screen.



- a. Select the desired Mode, Monitor or Operator
Monitor mode (default): user cannot operate HMI.
Operator mode: user can operate HMI.

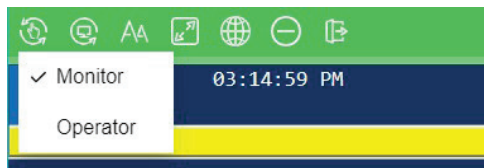

*Note – The screen displayed will be the same on the Remote Client and the HMI.

- b. Refresh Data Connection
- c. Select Font Size
- d. Select Scaling Mode
- e. Select Application Language (Not used in this application)
- f. Hide Toolbar
- g. Logout
- h. Communication Status
- i. Current Monitor/Operator Mode

Setpoints

When selecting the Setpt tab, the user will have the ability to adjust the factory settings for cleaning, airflow, airlock and motor timers. Each of these can be accessed by touching any one on the tabs on the right hand side of the screen. Factory settings should not be adjusted unless instructed to do so.

Cleaning

To enter cleaning mode, select the Setpt navigation tab. Options available in Setpt mode will display along right side of screen (referred to as Flags) and include Cleaning, Airflow, Airlock, Motor Timers and Defaults.

The screenshot displays the 'Setpoints' screen for 'Cleaning' mode. The top navigation bar includes 'Logout', 'Home', 'Trends', 'Alarms', 'Setpt' (selected), 'Maint', 'Config', and 'Diag'. The main content area is divided into two sections: 'Cleaning Mode' and 'Differential Pressure and On-Demand Cleaning Setpoints ("WC)'. The 'Cleaning Mode' section includes a dropdown menu for 'Continuous' (labeled 1 and 2), and 'Valve Pulse Setpoints' with fields for 'Max Cleaning Time Before Alarm Occurs' (30 Min, labeled 3), 'Downtime Duration' (2 Min), 'Fail to Start' (180 Sec), and 'Pulse ON Duration' (100 mSec). The 'Differential Pressure and On-Demand Cleaning Setpoints ("WC)' section includes fields for 'High Region of Interest' (10 "WC, labeled 4), 'High Pressure Alarm' (6.0 "WC), 'High Cleaning' (4.0 "WC), 'Low Cleaning' (0.1 "WC), 'Low Pressure Alarm' (0.0 "WC), and 'Low Region of Interest' (0.0 "WC). On the right side, there is a vertical menu with buttons for 'Cleaning', 'Airflow', 'Airlock', 'Motor Timers', and 'Defaults'.

1. **Cleaning Mode** selection with current selection indication.
2. **Cleaning Mode Options** - Options are accessed by selecting the pull down menu. See drop down menu details on next image.
 - a. **Downtime Only** cleans for a set duration after system has been stopped.
 - b. **Continuous** cleans continuously while system is running.
 - c. **Continuous and Downtime** cleans while system is running and for a set duration upon shutdown.
 - d. **Disabled** turns off all cleaning options.

3. Valve Pulse Setpoints - Pulse OFF Time is not adjustable and is calculated based on the cleaning arm position and the spoke setting.
 - a. **Max Time Before Alarm** length of time system is cleaning before triggering an alarm.
 - b. **Downtime Duration** (1-240 minutes) Number of minutes that down time cleaning is active after the collector is shut down
Note: A full cycle will pulse every filter which takes 4 minutes.
 - c. **Fail To Start** length of time after attempted start without running confirmation before alarming.
 - d. **Pulse ON** length of time pulse will be on.

4. **Cleaning Setpoints**
 - a. **High Region of Interest** (0 – 40 inches W.C.) highest value to be shown on bar graph or gauge.
 - b. **High Pressure Alarm** (0 – 40 inches W.C.) Alarm occurs when differential pressure is above this value, must be greater than High Cleaning Setpoint, shown red on graph or gauge.
 - c. **High Cleaning** (0 – 40 inches W.C.) If Cleaning mode is in On Demand, cleaning occurs when differential pressure is above this value, must be less than Alarm Setpoint and greater than Low Cleaning Setpoint, shown yellow on graph or gauge.
 - d. **Low Cleaning** (0 – 40 inches W.C.) If Cleaning mode is in On Demand, cleaning turns off when differential pressure is below this value, must be less than High Cleaning Setpoint, shown yellow on graph or gauge.
 - e. **Low Pressure Alarm** (0 – 40 inches W.C.) Alarm occurs when differential pressure is below this value, must be less than Low Cleaning Setpoint, shown red on graph or gauge.
 - f. **Low Region of Interest** (0 – 40 inches W.C.) lowest to be shown on bar graph or gauge.

Airflow

1. **Auto/Manual Mode** selection with current selection indication. Enables or disables Automatic Airflow Control.
2. If **Airflow Control** is set to **Manual Mode**, arrow buttons will appear allowing user to manually increase or decrease the VFD speed to control airflow.
3. **Indicators** show if a Speed Increase/Decrease is being requested in either Auto or Manual mode.
4. **Static Pressure** current value is displayed to show the real time effects of speed adjustments made in **Manual Mode** or for reference in **Auto Mode**.
5. **VFD Setpoints**
 - a. **High Pressure Alarm** Static Pressure value at which a High Pressure alarm is triggered.
 - b. **High Set** Static Pressure value at which VFD speed will decrease.
 - c. **Low Set** Static Pressure value at which VFD speed will increase.
 - d. **Low Pressure Alarm** Static Pressure value at which a Low Pressure alarm is triggered.

Airlock

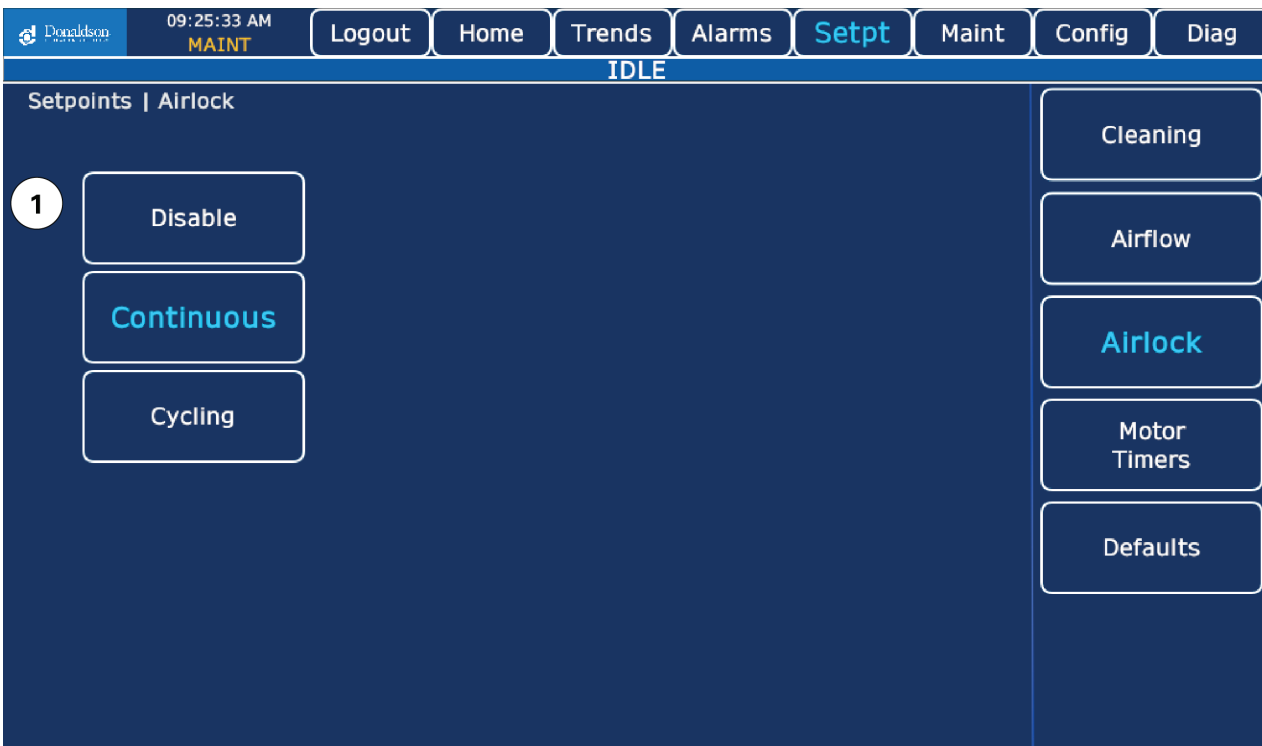

1. **Enable Mode** selection with current selection indication. Enables the airlock in Continuous (the device operates the entire time the collector is on) or Cycling (the device turns on and off at set intervals) mode or Disables the airlock.

Motor Timers

09:25:53 AM
MAINT

Logout Home Trends Alarms Setpt Maint Config Diag

IDLE

Setpoints | Motor Timers

	Start	Stop	Fault
1 (All times are in seconds)			
Main Blower	10	0	180
Manifold	3	0	2
PD Pump	3	60	2
Airlock	3	60	2
2 SCREW	0	60	2

Cleaning

Airflow

Airlock

Motor Timers

Defaults

1. **Timer Setpoints** are in seconds
 - a. **Start** is the Time Delay before the motor starts.
 - b. **Stop** is the Time Delay before a motor stops.
 - c. **Fault** is the length of time a motor has to indicate that it is running before generating a Fail to Run alarm.
2. **Aux Motors** are visible only when they have been enabled from the configuration screens.

Defaults

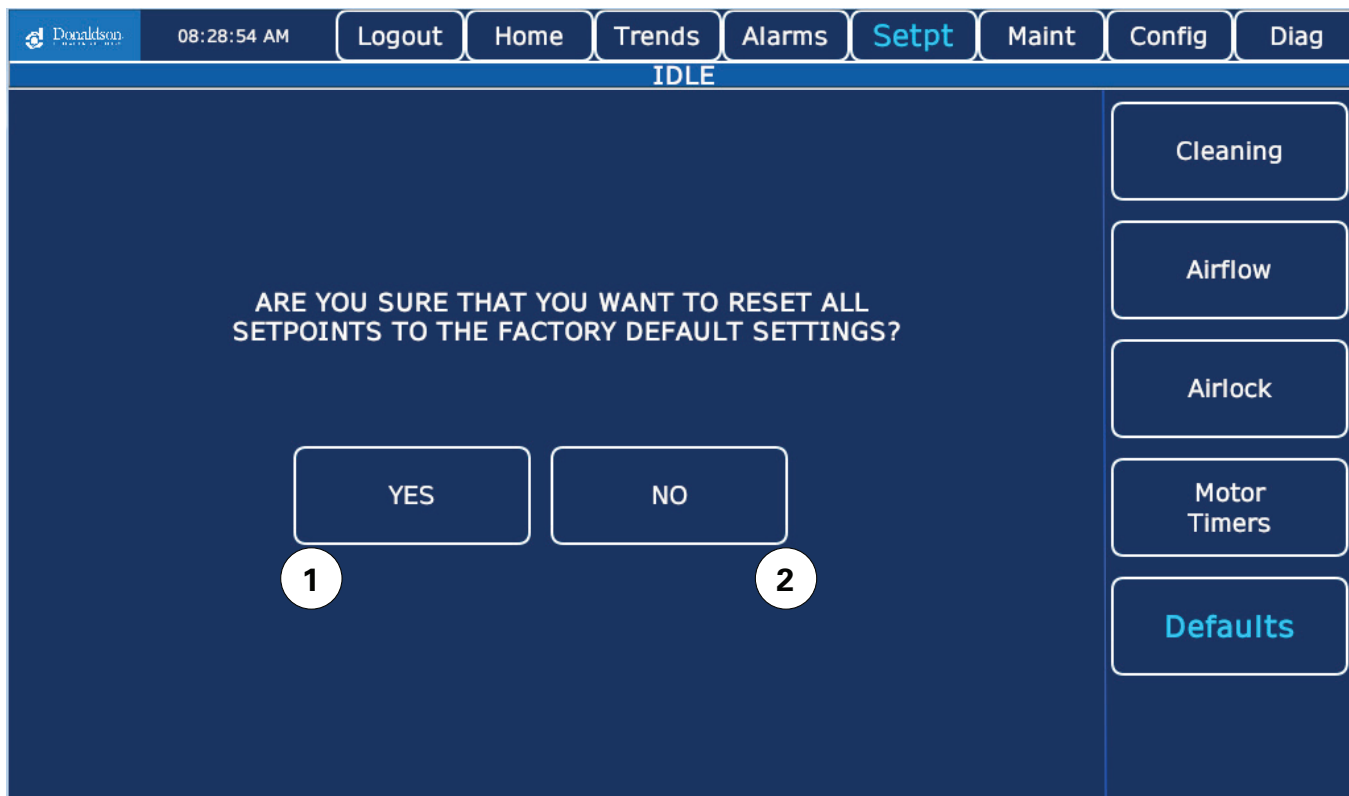

1. **Yes** resets all Options and Setpoints to Factory Defaults.
2. **No** cancels the request.

Maintenance

Motors

The screenshot shows the maintenance interface for a Blower motor. The top navigation bar includes 'Logout', 'Home', 'Trends', 'Alarms', 'Setpt', 'Maint', 'Config', and 'Diag'. The main area is titled 'Maintenance | Motors | Blower' and displays the motor status as 'IDLE'. On the left, there are three buttons: 'Auto' (1), 'Manual' (2), and 'Disable Alarms' (4). In the center, the status 'IDLE' (2) is shown above a green 'Start' button (3). Below the status, the 'Runtime Hours' are displayed as 66.98, with a 'RESET' button (5) next to it. On the right, a vertical list of motor options is shown: 'Blower', 'PD Pump', 'Manifold', 'Airlock', 'SCREW', 'M2', and 'M3'. A 'Motors' button is also visible on the far right.

1. **Auto/Manual Mode** Auto mode allows the system to start and stop the motor in sequence as configured. Manual mode allows the user to start and stop the motor as desired.
2. **Motor Status** displays the status of the motor.
3. **Start/Stop Buttons** are shown when the motor is in **Manual Mode**. If the motor is idle, the **Start** button will appear. If the motor is running the **Stop** button shows.
4. **Disable Alarms** allows user to disable alarms for the motor. When alarms are disabled for a motor it will be indicated on the home screen.
5. **Runtime Hours** shows running hours for the selected motor. The **RESET** button will clear this value setting it back to zero.
6. **Select** desired motor from list. **Aux Motors** will be visible if configured.

Pulse Cleaning Display

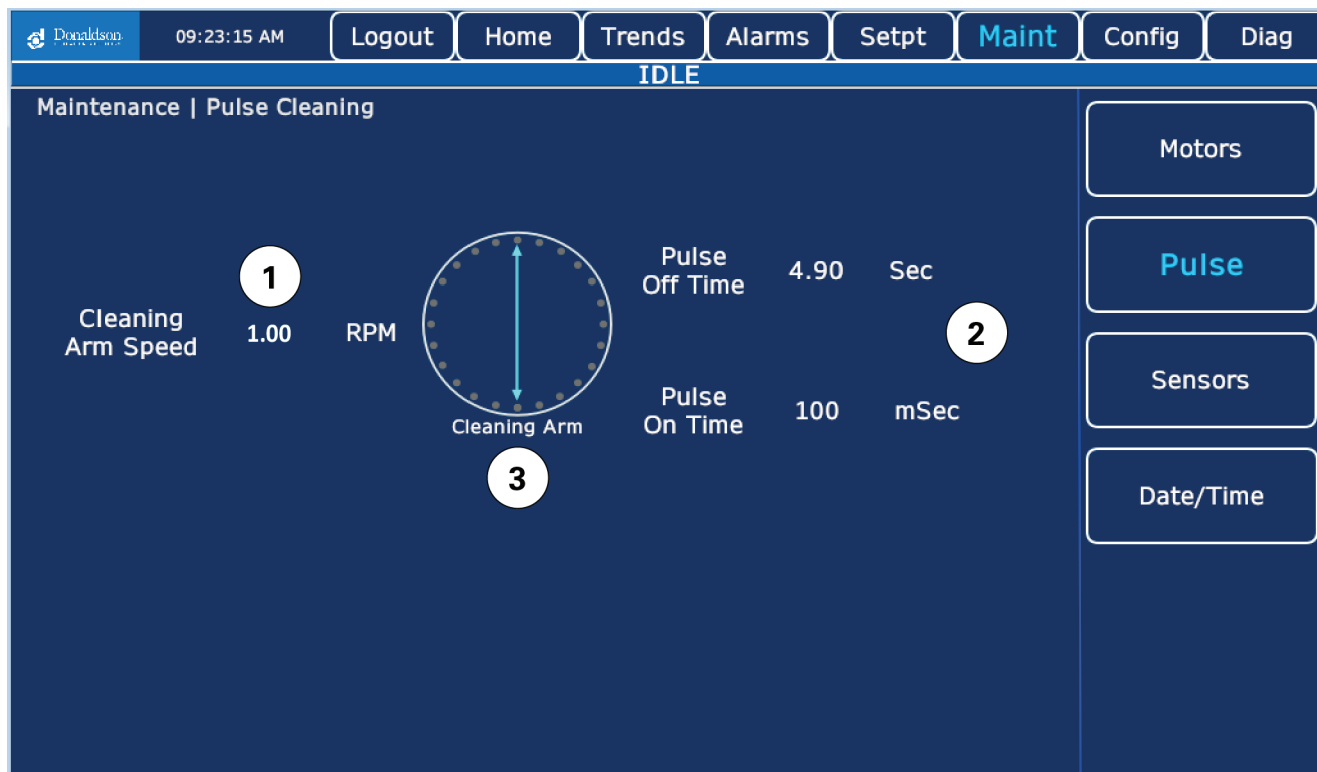

1. **Cleaning Arm Speed** displays the speed at which the cleaning arm last moved.
2. **Pulse Times** displays the values of the last pulse times.
3. **Cleaning Arm** shows the same animation and rotation as on the home screen.

RP Control Panel Pulse OFF Time (Reference Only)		
RP Model	Spoke Count	Pulse OFF TIME
72RP, 90RP 66RPH, 88RPH	24	10
136RP, 156RP, 200RP 132RPH, 150RPH, 188RPH	48	5.0
272RP 258RPH	96	2.5

Pressure Sensors

The screenshot shows the 'Maintenance | Sensors' interface for 'Differential Pressure'. It features a 'Simulate Signal' toggle switch (1) currently set to 'ON'. The 'Current Value' is 1.2 "WC" (2), and the 'Simulate Value' is also 1.2 "WC" (2). Below this, the 'Static Pressure' section shows a 'Current Value' of 0.0 "WC" (3) and a 'Simulate Signal' toggle switch currently set to 'OFF'. A sidebar on the right contains buttons for 'Motors', 'Pulse', 'Sensors', and 'Date/Time'.

1. **Simulate Signal** provides a test input which allows the user to simulate a pressure value for testing purposes. If the signal is in simulate mode, it is indicated on the home screen.
2. **Simulated Value** allows user to enter a value only when simulate signal is set.
3. **Current Value** shows the value the system is using for the signal whether simulated or actual.

Time and Date

The screenshot shows the 'Maintenance | Time & Date' configuration screen. At the top, the status is 'IDLE'. The current time and date are displayed as '11/15/2021 (Mon) 03:31:42'. Below this, there are input fields for Year, Month, Day, Hour, Minute, and Second, each with a value of '0'. A 'Date/Time' button is highlighted in blue, and an 'Update Time' button is visible. The interface includes a navigation bar with buttons for Logout, Home, Trends, Alarms, Setpt, Maint, Config, and Diag.

1. **Current Time and Date** shows the current time and date of the system.
2. **Enter New Values** allows user to enter new values for the Date and Time.
3. **Update Time Button** writes the new values to the system.

Configuration

Motors

This tab allows the user access to the configuration of pre-configured motors. If a motor change is required or additional motors are added after installation, please contact Donaldson for further instruction.

The screenshot displays the HMI configuration interface for motors. At the top, a navigation bar includes buttons for Logout, Home, Trends, Alarms, Setpt, Maint, Config (highlighted), and Diag. The time 08:32:21 AM is shown. Below the navigation bar, the status 'IDLE' is displayed. The main content area is titled 'Configuration | Motors | Blower' and is divided into three columns. The left column contains 'Enabled' and 'Disable' buttons, with a circled '1' next to the 'Enabled' button. The middle column contains 'Motor Starter', 'Soft Start', and 'VFD' buttons, with a circled '2' next to the 'Soft Start' button. The right column contains a list of motor types: 'Blower', 'PD Pump', 'Manifold', 'Airlock', 'SCREW', 'M2', and 'M3', with a circled '3' next to the 'SCREW' button. A separate 'Motors' panel on the far right contains 'Auxiliary Alarms', 'Pressure Sensors', 'Spoke Settings', and 'HMI Configuration' buttons.

1. **Enable** indicates to the system if the motor is to be used.
2. **Motor Type** allows selection of the motor configuration for the given motor.
3. **Select** desired motor from list. **Aux Motors** will be visible if configured.

Aux Motors

This tab allows the user access to the configuration of pre-configured aux motors. If an aux motor change is required or additional aux motors are added after instalalton, please contact Donaldson for further instruction.

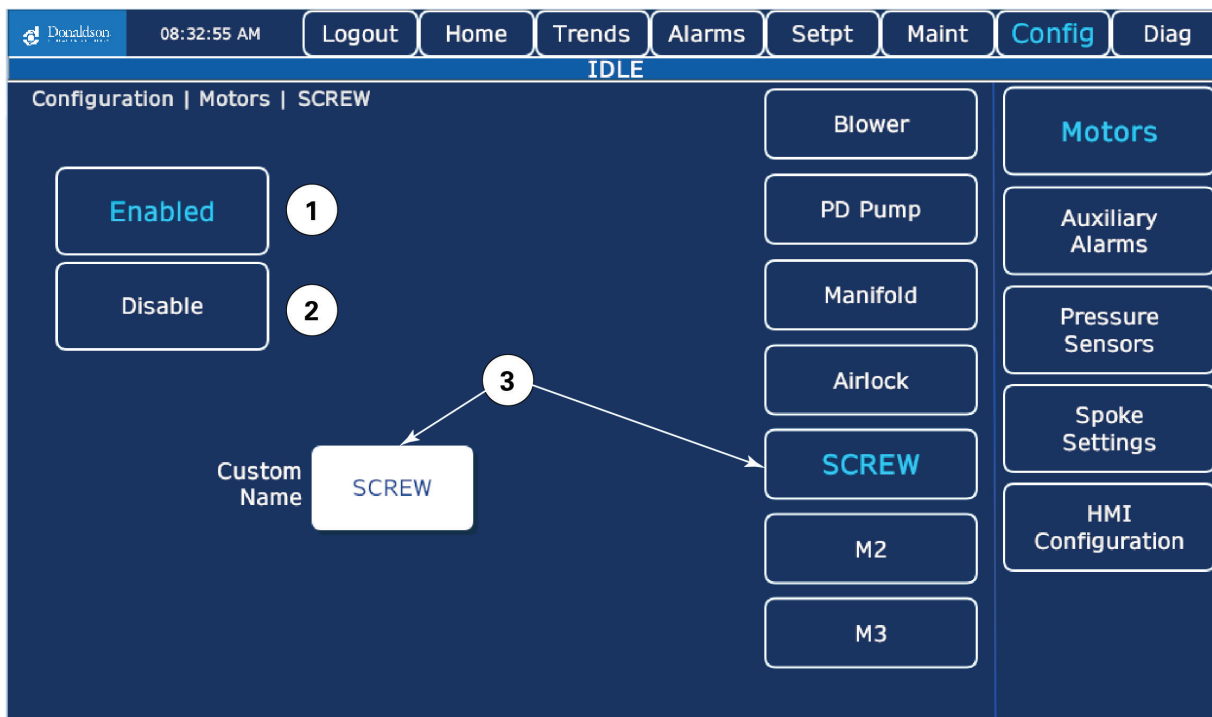

1. **Enable** indicates to the system if the motor is to be used.
2. **Disabled** motors will not be used or shown.
3. **Custom Name** allows user to enter a custom name to be used for the motor throughout the system.

Aux Alarms

This tab allows the user access to the configuration of pre-configured aux alarms. If an aux alarm change is required or additional aux alarms are added after instalalton, please contact Donaldson for further instruction.

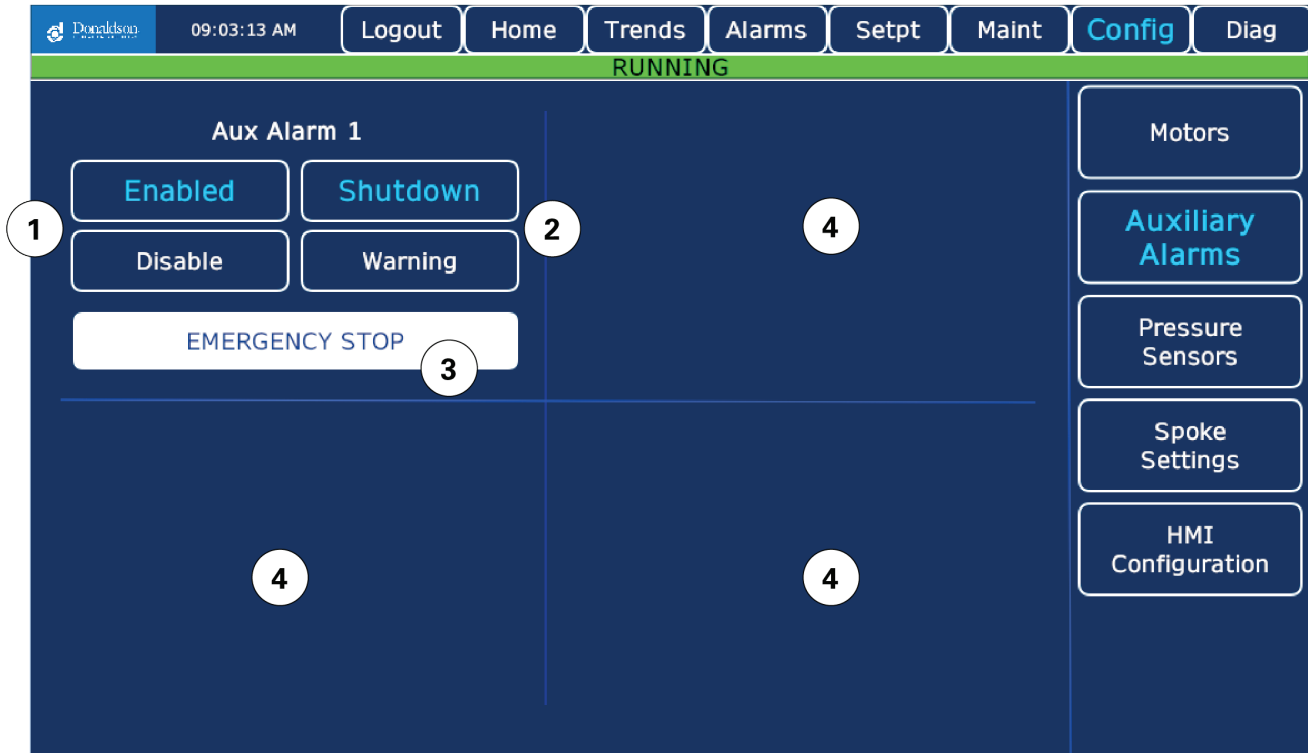

1. **Enable** indicates to the system if the alarm is to be used.
2. **Alarm Action** tells the system what action to take when the alarm is active.
3. **Alarm Description** text is shown in the Aux Alarm legend on the Alarm screen for reference.
4. **More Alarms** can be configured in the PLC.

Spokes

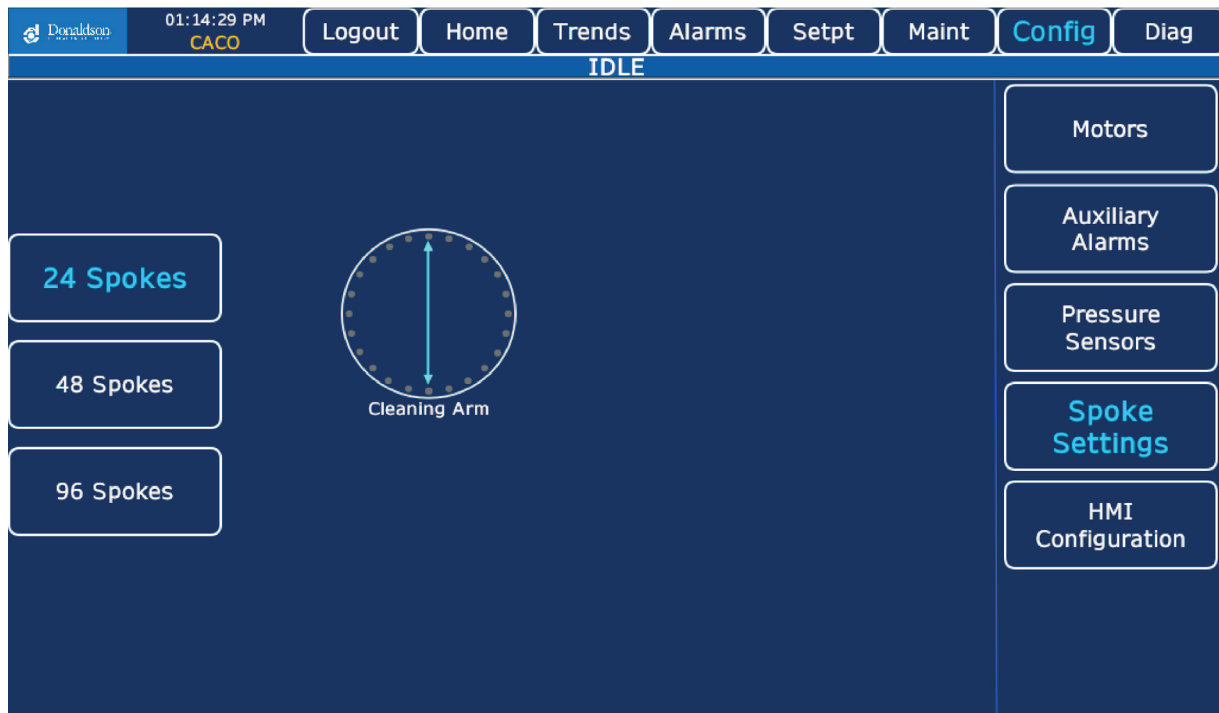

1. **Spoke Count** sets the number of Spokes on the cleaning arm. Reference table below.
2. **Cleaning Arm** displays the number of spokes selected. Rotation and animation is also shown

RP Spoke Count	
RP Model	Spoke Count
72RP, 90RP 66RPH, 88RPH	24
136RP, 156RP, 200RP 132RPH, 150RPH, 188RPH	48
272RP 258RPH	96

HMI

HMI Configuration allows user to adjust the date and time, screen brightness and enable or disable the touch buzzer.

The screenshot displays the HMI Configuration interface. At the top, a navigation bar includes the Donaldson logo, the time 08:33:30 AM, and buttons for Logout, Home, Trends, Alarms, Setpt, Maint, Config (highlighted), and Diag. Below the navigation bar, the status 'IDLE' is shown. The main configuration area is titled 'Configuration' and contains several sections: 'Date/Time' with a display showing '11/15/2021 (Mon) 08:33:30'; 'Touch' with a 'Buzzer' section containing 'Enable', 'Disable', and '...' buttons; 'Brightness' with a slider and '-' and '+' buttons; 'Ethernet1' with a 'Save and Reboot' button and a '...' button; and 'Ethernet2' with 'Up' and 'Down' status indicators. On the right side, a vertical sidebar contains buttons for 'Motors', 'Auxiliary Alarms', 'Pressure Sensors', 'Spoke Settings', and 'HMI Configuration' (highlighted in blue).

Diagnostics

Digital Inputs

The screenshot displays the 'Digital Inputs' section of the control panel. At the top, the system status is 'IDLE' and the cleaning type is 'RF'. The list of inputs is as follows:

Point Number	Status	Description
0	Off	BLOWER VFD RUNNING
1	Off	PD PUMP RUNNING
2	Off	MANIFOLD RUNNING
3	Off	ROTARY AIRLOCK RUNNING
4	Off	SCREW CONVEYOR RUNNING
5	Off	SPARE_05
6	Off	REMOTE START/STOP
7	Off	SPARE_07
8	Off	SPARE_08
9	Off	SPARE_09
10	Off	SPARE_10
11	Off	MANIFOLD ARM SENSOR
12	Off	SPARE_12
13	Off	SPARE_13
14	Off	SPARE_14
15	Off	SPARE_15
16	Off	SPARE_16
17	Off	SPARE_17
18	Off	SPARE_18
19	Off	SPARE_19
20	Off	SPARE_20
21	Off	SPARE_21
22	Off	SPARE_22
23	Off	EMERGENCY STOP MONITOR

On the right side of the screen, there are several navigation buttons: Digital Inputs, Digital Outputs, Analog Inputs, Hardware Status, Software Status, and About.

1. **Input Point** indicates point number on the input card.
2. **Status** indicates by color change if the point is on (green) or off (grey).
3. **Description** indicates the device that provides the input signal.

Digital Outputs

08:33:58 AM Logout Home Trends Alarms Setpt Maint Config Diag

IDLE

Cleaning Type : RF

Point Number	Status	Description
0	Grey	SOLENOID VALVE
1	Grey	SPARE_01
2	Grey	SPARE_02
3	Grey	SPARE_03
4	Grey	MAIN BLOWER RUN
5	Grey	PD PUMP RUN
6	Grey	MANIFOLD DRIVE RUN
7	Grey	ROTARY AIRLOCK RUN
8	Grey	SCREW CONVEYOR RUN
9	Grey	SPARE_09
10	Grey	SPARE_10
11	Grey	ALARM BEACON ON
12	Grey	INCREASE VFD SPEED
13	Grey	DECREASE VFD SPEED
14	Green	MAIN BLOWER ENABLE
15	Grey	ALARM HORN ON

Digital Inputs

Digital Outputs

Analog Inputs

Hardware Status

Software Status

About

1. **Output Point** indicates point number on the output card.
2. **Status** indicates by color change if the point is on (green) or off (grey).
3. **Description** indicates the device controlled by the specific pin.

Analog Inputs

Donaldson 08:34:09 AM Logout Home Trends Alarms Setpt Maint Config Diag

IDLE Cleaning Type : RF

0	0.0	DIFFERENTIAL PRESSURE
1	0.0	STATIC PRESSURE

Digital Inputs

Digital Outputs

Analog Inputs

Hardware Status

Software Status

About

1. **Analog Point** indicates point number on the input card.
2. **Value** indicates current input value in mA.
3. **Description** indicates the device that provides the input signal.

Hardware Status

Hardware Description	Value
Controller State	RUNNING
PLC I/O Status	OK
TM3 I/O Status	UNKNOWN STATUS
TM3 Bus Status	UNKNOWN STATUS
AI Module Status	EMPTY
AO Module Status	EMPTY
PLC Part Number	TM241CE40R
PLC Serial Number	9859
PLCFirmware	5.0.8.4
PLC Node Name	Collector
Battery Level %	100
SD Card Status	NO SD CARD

1. **Hardware Description** indicates what hardware value is being displayed.
2. **Value** indicates current value.

Software Status

Donaldson 08:34:28 AM Logout Home Trends Alarms Setpt Maint Config Diag

IDLE

Cleaning Type : RF

1 HMI Version Number	ST6_DCI_V5s	2
PLC Project Runtime Version Major	3	
PLC Project Runtime Version Minor	5	
Main Task Step Number	100	
Main Task Scan Rate	10	ms
Pulsing Task Step Number	100	
Pulsing Task Scan Rate	0	ms

Digital Inputs

Digital Outputs

Analog Inputs

Hardware Status

Software Status

About

1. **Software Description** indicates what software value is being displayed.
2. **Value** indicates current value.

Modes of Operation

1. **Auto Mode** - Airlock, Manifold, along with any configured Auxiliary motors start using the System Start/Stop buttons. The Manifold Drive and PD pump runs along with the Blower if the Collector pulse cleaning is in a Continuous mode.
2. **Manual Mode** - Each motor that is in manual mode can be started or stopped independently.

Note: If any of the motor are in Manual mode, the Auto mode starting is not allowed.

Auto Mode

Starting and Continuous Cleaning Mode

1. Note: If any of the motors are in Manual mode, Auto Mode starting is not allowed.
2. When the System START button on the HMI Home screen is pressed the collector motors will sequentially start using the following sequence:
 - a. **Auxiliary Motors** - Aux Motors will be started in reverse order (3, 2, 1). If the motor is enabled the start delay timer will start. When the start delay has finished the motor will be requested to run. When the motor is running the indicator turns green on the HMI Home screen. If the motor fails to start, an alarm will be triggered and the indicator will turn red.
 - b. **Airlock** - After all aux motors have been started, the Airlock start delay timer will start. When the start delay has finished the Airlock will be requested to run. When the Airlock is running the indicator turns green on the HMI Home screen. If the Airlock fails to start, an alarm will be triggered and the indicator will turn red.
 - c. **Manifold** - After the Airlock is running, the Manifold start delay timer will start. When the start delay has finished, the Manifold will be requested to run. When the Manifold is running the indicator turns green on the HMI Home screen. If the Manifold fails to start, an alarm will be triggered and the indicator will turn red.
 - d. **Cleaning** - will start based on the Perfect Pulse Logic for the number of configured Radial Spokes Tube Sheet Configuration.
 - e. **PD Pump** - After cleaning has started the PD Pump start delay timer will start. When the start delay has finished, the PD Pump will be requested to run. When the PD Pump is running the indicator turns green on the HMI Home screen. If the PD Pump fails to start, an alarm will be triggered and the indicator will turn red.
 - f. **Blower** - After the PD Pump is running the Blower start delay timer will start. When the start delay has finished, the Blower will be requested to run. When the Blower is running the indicator turns green on the HMI Home screen. If the Blower fails to start, an alarm will be triggered and the indicator will turn red.

Stopping the Collector

1. When the System STOP button on the HMI Home screen is pressed the cleaning motors will sequentially stop using the following sequence:
 - a. **Blower** - The Blower stop delay timer will start. When the stop delay timer has finished, the Blower will be requested to stop. When the Blower is stopped the indicator will turn blue on the HMI Home screen. If the Blower fails to stop, an alarm will be triggered and the indicator will turn red.
 - b. **Down Time Cleaning** - if enabled, the Down Time Cleaning timer will start. The Airlock, PD Pump, and Manifold Drive will continue running for the duration of the Down Time Cleaning.
 - c. **Manifold** - When the Down Time Cleaning timer has finished or if Down Time Cleaning is disabled and the Blower has been stopped, the Manifold stop delay timer will start. When the Manifold stop delay timer has finished, the Manifold will be requested to stop. When the Manifold is stopped the indicator will turn blue on the HMI Home screen. If the Manifold fails to stop, an alarm will be triggered and the indicator will turn red.
 - d. **PD Pump** - When the Manifold has been stopped, the PD Pump stop delay timer will start. When the PD Pump stop delay timer has finished, the PD Pump will be requested to stop. When the PD Pump is stopped the indicator will turn blue on the HMI Home screen. If the PD Pump fails to stop, an alarm will be triggered and the indicator will turn red.
 - e. **Airlock** - When the PD Pump has been stopped, the Airlock stop delay timer will start. When the Airlock stop delay timer has finished, the Airlock will be requested to stop. When the Airlock is stopped the indicator will turn blue on the HMI Home screen. If the Airlock fails to stop, an alarm will be triggered and the indicator will turn red.
 - f. **Aux Motors** - When the Airlock has stopped, the Aux Motors will stop in order (1, 2, 3). When the previous motor has stopped, the Motor stop delay timer will start. When the stop delay timer has finished, the Motor will be requested to stop. When the motor is stopped, the indicator will turn blue on the HMI Home screen. If the Motor fails to stop, an alarm will be triggered and the indicator will turn red.

Troubleshooting

Problem	Probable Cause	Remedy
Motor Alarm Failed to Start	Motor starter or VFD did not signal the controller that the motor had started	Check and correct motor starter/VFD overload settings and run status (remote/local).
	Motor starter or VFD not properly configured	Check and correct signal wiring between PLC and motor starter/VFD.
	Motor under excessive load	Check and correct all power connections at the motor starter/VFD and at the motor.
	Bad communications between starter or VFD and PLC	Check for blocked or inoperable driven equipment and correct as needed. Acknowledge alarm and attempt to start the system. If the problem persists contact Donaldson Torit.
Motor Alarm Failed to Run	Motor starter or VFD started, but the motor starter/VFD fails to stay in the running state	Check and correct motor starter/VFD overload settings (remote/local).
	Motor starter or VFD not properly configured	Check and correct signal wiring between PLC and motor starter/VFD.
	Motor under excessive load	Check and correct all power connections at the motor starter/VFD and at the motor.
	Bad communications between starter or VFD and PLC	Check driven components for excess drag or lack of lubrication and correct as needed. Acknowledge alarm and attempt to start the system. If the problem persists contact Donaldson Torit.
Motor Alarm Failed to Stop	Motor has been requested to stop but continues running after the configured STOP time has elapsed	Check and correct signal wiring between PLC and motor starter/VFD. Acknowledge alarm and attempt to start the system. If the problem persists contact Donaldson Torit.
PLC/HMI Specific Alarms	Communication issues between HMI and PLC	Contact Donaldson Torit.
High Differential Pressure	Clogged pressure line	Check all pressure lines for blockage between controller and collector.
	Improper setting for High Pressure Alarm	Only blow into lines toward the collector (excess pressure will damage sensors, check for other devices connected to pressure lines before blowing out the blockage).
	Cleaning disabled	Check setting for High Differential Pressure alarm and review for suitability in the application (permitting may require a certain value to be used).
	Cleaing system not functioning correctly	Check cleaning status and adjust as needed (some applications only use downtime cleaning).
	Filters have reached end of life	Verify operation of cleaning system components and status of the air supply for pulse cleaning. Remove and replace using genuine Donaldson replacement filters as needed or required by site defined process. See Filter Replacement in RP Control Panel installation and operation manual.

Problem	Probable Cause	Remedy
Low Differential Pressure	Clogged pressure line	Check all pressure lines for blockage between controller and collector.
	Improper setting for Low Pressure Alarm	Only blow into lines toward the collector (excess pressure will damage sensors, check for other devices connected to pressure lines before blowing out the blockage).
	Filter bypass	Check setting for Low Differential Pressure alarm and review for suitability in the application (permitting may require a certain value to be used). Check for filter bypass and diagnose the cause if bypass is found.
Differential Pressure Underrange	Clogged pressure line	Check all pressure lines for blockage between controller and collector.
	Poor connection to pressure sensors	Only blow into lines toward the collector (excess pressure will damage sensors, check for other devices connected to pressure lines before blowing out the blockage). Check connection between pressure sensors and PLC.

Appendix A - Installation

Installation



Electrical Installation (including bonding and grounding of the collector) must be performed by a qualified electrician.

Do not install in classified hazardous atmospheres without an enclosure rated for the application.

Service must be performed by trained and qualified maintenance personnel.

Turn all power off and lock out all power before performing service or maintenance work. It is not unusual for the equipment to be operated from a remote location, so equipment may start or stop unexpectedly.

Location and Site Selection



Codes may regulate recirculating filtered air in your facility. Consult with the appropriate authorities having jurisdiction to ensure compliance with all national and local codes regarding recirculating filtered air.

Equipment location must conform to all codes and standards, should be suitable for the type of dust being handled and should ensure easy access for service and utility connections. Site selection must account for wind, seismic zone and other load conditions.

Delivery and Inspection

Upon arrival inspect equipment and report any damage to delivery carrier. File any damage claims with the delivery carrier. Request a written inspection report from the Claims Inspector to substantiate all damage claims.

Compare the equipment received with the description of product ordered. Report any incomplete shipments to the delivery carrier and your Donaldson Torit representative.

Unloading and Positioning



Equipment should be lifted only by qualified crane or fork truck operators.

Failure to lift the equipment correctly can result in severe personal injury and/or property damage.

1. Remove any crates or shipping straps.
2. Lift the packaged collector from transport container.
3. Inspect for any damage and/or missing parts and report to freight carrier.
4. Check for any hardware which may have become loose during shipment and tighten as necessary.

Electrical Wiring



Electrical installation, service, or maintenance work must be performed by a qualified electrician and comply with all applicable national and local codes.

Turn all power off and lock out all power before performing service or maintenance work. It is not unusual for the equipment to be operated from a remote location so equipment may start or stop unexpectedly.

The appropriate wiring schematic and electrical rating must be used. See collector's rating plate for required voltage.

Do not install in classified hazardous atmospheres without an enclosure rated for the application.

1. Choose a suitable location that permits access and observation to the keypad for adjustments and observation of the pressure drop. If possible, mount the control indoors.

NOTICE

Use vibration isolators in high vibration areas.

2. Using the wiring diagram provided with the control panel, make the wiring connections.

Solenoid Connection

The collector is equipped with a solenoid valve (typically 120V) that controls the pulse-cleaning valve, which cleans the filters.

Input

102-132V/50-60Hz/1Ph

20.9 watts @ 120V/60 Hz intermittent duty

Pulse ON Time

Factory set at 100-milliseconds, or 1/10-second (not field adjustable)

Pulse OFF Time

Factory set, the OFF time is dictated by the arm rotation speed and collector model. Refer to the table below when setting pulse only controller (PLC only).

NOTICE

Open the valve to the air reservoir gauge only when verifying pulse pressure and ensure the system is in the normal pulse operation if using a pulse only controller.

Model	Setting
66RPH, 72RP, 88RPH, 90RP	24 Spokes
132RPH, 136RP, 150RPH, 156RP, 188RPH, 200RP	48 Spokes
258RPH, 272RP	96 Spokes

Operating Temperature Range

-20° F to 180° F

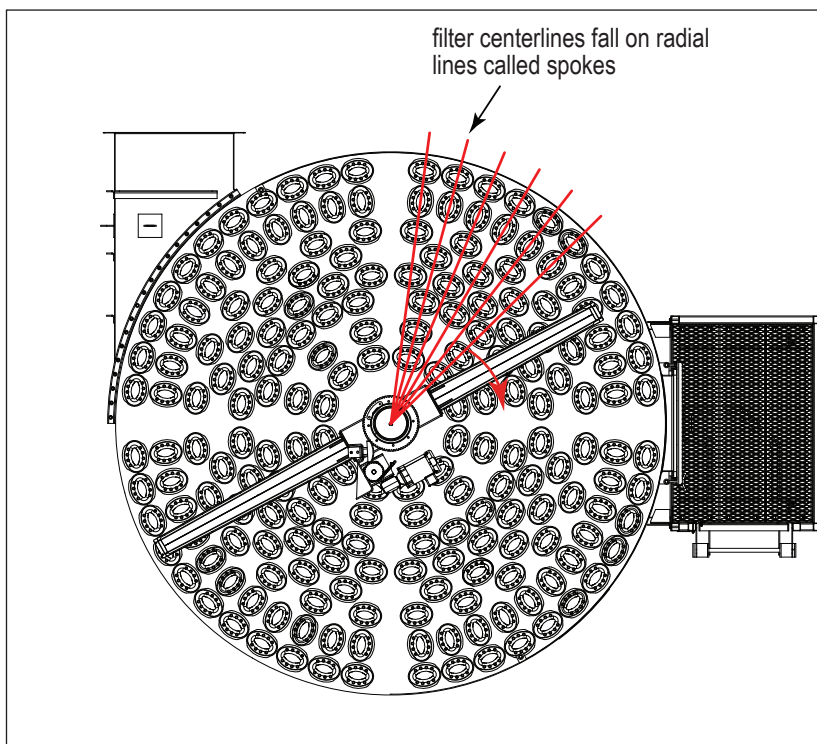

RP collectors ordered with a control panel will have a specific drawing to follow that ships with the RP control panel.

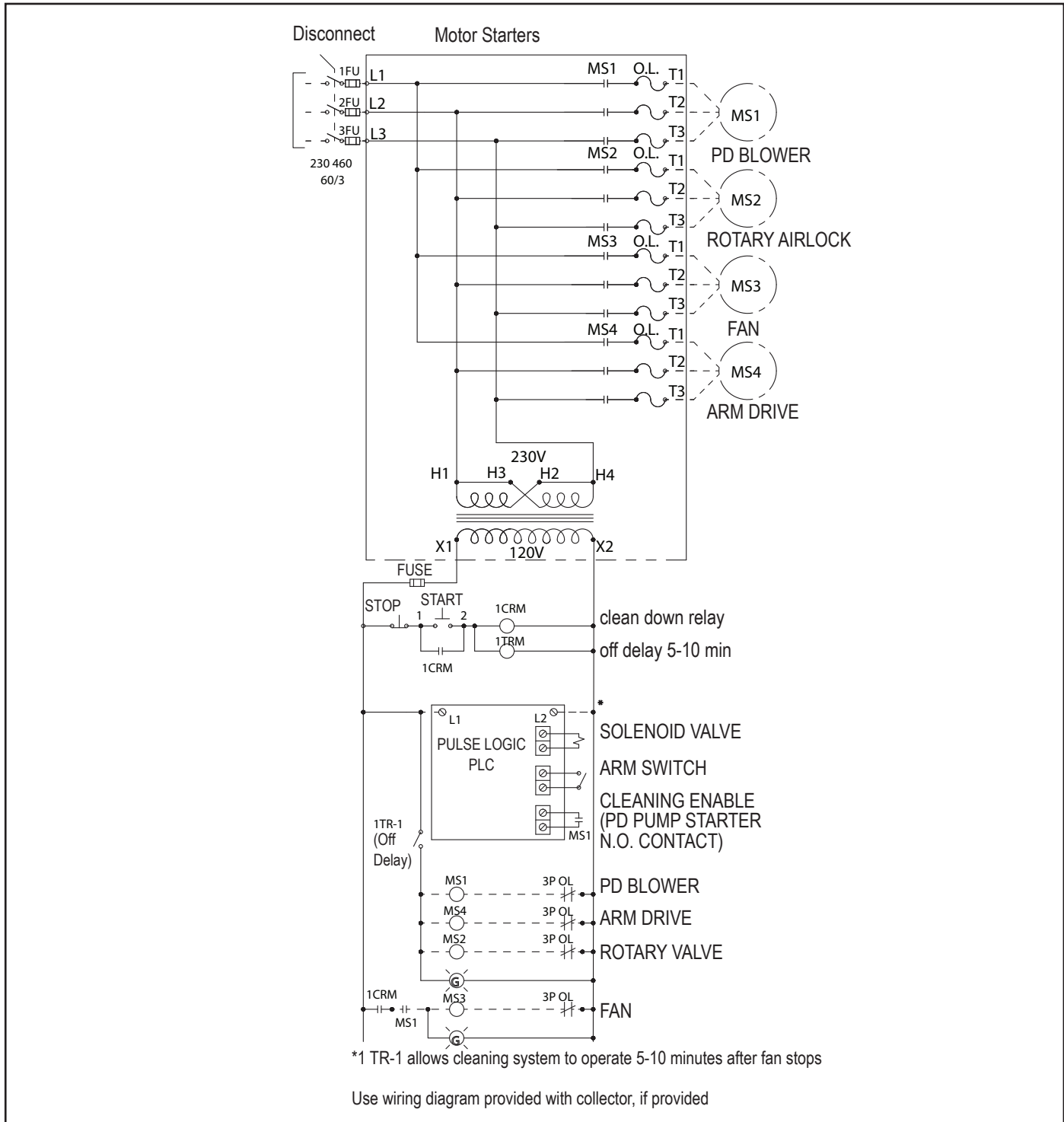

Typical Wiring Diagram

Start-up / Commissioning

Instruct all personnel on safe use and maintenance procedures.



Electrical installation, service, or maintenance work must be performed by a qualified electrician and comply with all applicable national and local codes. This equipment may start or stop unexpectedly from a remote location.

Turn power off and lock out all power before performing service or maintenance work.

Turn compressed air supply OFF, bleed and lock out lines before performing service or maintenance work.

Check that the collector is clear and free of all debris before starting.

Do not install in classified hazardous atmospheres without an enclosure rated for the application.

1. Check all electrical connections for tightness and contact.
2. Check for proper rotation on all motors as described below.



Do not look into fan outlet to determine rotation. View the fan rotation through the back of the motor.

Check that the exhaust plenum is free of tools or debris before checking fan rotation.

Stand clear of exhaust to avoid personal injury.

Do not interchange a power lead with the ground wire. Severe personal injury and/or property damage may result.

- a. Bump the fan to initiate rotation.
- b. As the fan is winding down (unpowered) compare fan rotation to the rotation label (located on fan housing) direction.
3. If the fan rotation is reversed, correct the rotation.
 - a. Lock-Out all energy sources.
 - b. Within the junction box, swap the connection location of two power leads on the terminal block, making certain not to swap a power lead and the ground wire.

To reverse rotation, single-phase power supply: Follow manufacturer's instructions on the motor's nameplate. To reverse rotation, three-phase power supply: Switch any two leads on the motor junction box.



Do not interchange a power lead with a ground wire or severe personal injury and/or property damage may result.

4. Ensure all equipment access panels are sealed and secure.
5. Check that the hopper discharge system is properly sealed as needed to keep the collector under operating pressure.
6. Check that fan exhaust damper (if applicable) is set to the fully-closed position.
7. Check and remove all loose items in or near the inlet and outlet of the collector.
8. Check that all remote controls and system components are properly wired and all service switches are in the OFF position.
9. Check that all optional accessories are installed properly and secured.
10. Ensure all filters are installed and properly seated in the tubesheet.
11. Turn power ON at source.
12. Turn powered hopper discharge devices ON.
13. Turn pulse system ON.
14. Turn fan motor ON.
15. Adjust airflow with the Airflow Controller or exhaust damper.

NOTICE

Excess airflow can shorten filter life, cause electrical system failure and fan motor failure.

16. Ensure fire mitigation system water is installed and functioning correctly, if present.

Decommissioning

Once the collector has reached the end of operational life it will need to be decommissioned.



During decommissioning, there is potential for exposure to the dust in the collector. Most dusts present safety and health hazards that require precautions. Wear eye, respiratory, head, and other protection equipment suitable for the type of dust when performing any decommissioning activities.

LOCK-OUT all energy sources prior to performing any decommissioning activities on the equipment.

Electrical service must be performed by a qualified electrician.

Disconnection of ducts must be performed by a qualified contractor.

1. Follow the typical shut-down sequence steps located in the operation section to remove as much contaminant from collector as possible.
2. Lock-Out all energy sources to the collector, material handling system and other associated equipment.
3. Remove all filters from the collector and dispose of in a suitable fashion for the dust in the collector. (See Filter Replacement for removal instructions).
4. Disconnect electrical power from the collector and material handling system components and remove any associated conduit or hardware from the exterior of the collector.
5. Clear residual dust accumulations from surfaces inside the collector and associated components in a fashion suitable for the dust, prior to further disassembly.
6. Remove and dispose of all material handling components from the collector hopper discharge.
7. Disconnect all ducts from the collector.
8. Proceed to disassemble collector by removing sub-assemblies in the reverse order of the steps given in Appendix A.
Note: The clean air plenum, dirty air plenum, tube sheet and cleaning assembly may be removed in separate steps instead of as one unit.
9. Once all cross bracing has been taken down, remove anchor bolts and lower leg pack columns.
10. Secure all collector components to a suitable transport carrier and transport to a disposal site suitable for the dust in the collector.

Appendix B - Quick Start Procedure

Quick Start Procedure

Instruct all personnel on safe use and maintenance procedures.



Electrical installation, service, or maintenance work must be performed by a qualified electrician and comply with all applicable national and local codes. This equipment may start or stop unexpectedly from a remote location.

Turn power off and lock out all power before performing service or maintenance work.

Turn compressed air supply OFF, bleed and lock out lines before performing service or maintenance work.

Check that the collector is clear and free of all debris before starting.

Do not install in classified hazardous atmospheres without an enclosure rated for the application.

The Quick Start Procedure is not a replacement for following the complete instructions found in this manual and is intended for general application only. Additional setup or changes may be required depending on your application.

Motors and control devices should be wired before starting the Quick Start Procedure.

Typical sequence shown for RP collectors with continuous cleaning, rotary airlock, and VFD airflow control.

Steps

1. **Login** as Manager/DCI
2. **Motor Configuration** navigate to **Config>Motors** setup any additional motor starters NOT supplied with the panel but will need to be sequenced by the main panel.VFD .
 - a. PD PUMP VS PD BLOWER. ASSUMPTION IS PUMP LIKE RF RP AND BLOWER LIKE LP
 - b. Enabling additional motors will allow the controller to send a 24VDC signal to external motor controls and will require a no contact from the motor controller to close on start.
3. **Rotation Check** Navigate to **Maint>Motors**, place each, motor in Manual Mode, start and stop checking for rotation.
4. **Enable Aux Alarms** Navigate to **Configs>Auxillary Alarms**
5. **Configure Spoke Count** Navigate to **Configs>Spokes**
 - a. Set spoke count based on the collector size.
 - b. 24 SPOKES – 66RPH, 72RP, 86RPH, 90RP
 - c. 48 SPOKES – 132RPH, 136RP, 150RPH, 156RP, 188RPH, 200RP
 - d. 96 SPOKES – 258RPH, 272RP

6. Set Cleaning Operation Navigate to **Setpt>Cleaning**

- a. Set cleaning operation
 - i. Set to continuous with or without downtime
 - ii. Set the downtime cleaning to run for 12minutes for 3 full cycles
- b. Set pressures for cleaning (This is to adjust the display on the home screen. The cleaning will run continuously when set to continuous.)
 - i. Set minimum to 0
 - ii. Low alarm 0.1
 - iii. Low 0.2
 - iv. High 4.0
 - v. High alarm 6.0
 - vi. High value 6.0

7. Set Airflow Navigate to **Setpt>Airflow**

- a. Set airflow (only for VFD)
 - i. Disable airflow controller by pressing the DISABLED button.
 - ii. You will now be controlling the airflow with the UP and DOWN arrows.
- b. At this time, you will need to START the dust collector. To properly set the airflow, the system airflow will need to be measured and that information will guide you on how to adjust the system to get the designed airflow. The value may need to be changed as the system evolves.
- c. While monitoring airflow with a pitot tube, manually adjust the airflow using the up and down arrows
- d. Once the desired airflow is achieved, note the static pressure
- e. Adjust the setpoints on this menu to the information below
 - i. Increase (noted value -0.2")
 - ii. Decrease (noted value +0.2")
 - iii. Alarm setpoints should be adjusted as needed for the site
- f. Press the ENABLED button to allow the airflow controller to automatically adjust the airflow based on the parameters entered.

8. Setup Airlock Navigate to **Setpt>Airlock**

For typical applications and rotary airlocks such as AN valves or cast body airlocks, use the continuous mode.

Product Information

(Process Owner to complete and retain for your records)

Model Number _____	Serial Number _____
Ship Date _____	Installation Date _____
Filter Type _____	
Collected Dust _____	
Dust Properties: Kst _____	Pmax _____ MIE _____ MEC _____
Accessories _____	
Other _____	

Donaldson Industrial Air Filtration Warranty

Donaldson warrants to the original purchaser only that the Goods will be free from defects in material and manufacture for the applicable time periods stated below: (1) Major structural components for a period of ten (10) years from the date of shipment; (2) Non-Structural, Donaldson-built components and accessories including Donaldson Airlocks, TBI Fans, TRB Fans, Fume Collector products, Donaldson built electrical control components, and Donaldson-built Afterfilter housings for a period of twelve (12) months from date of shipment; and (3) Donaldson-built filter elements for a period of eighteen (18) months from date of shipment.

Buyer is solely responsible for determining if goods fit Buyer's particular purpose and are suitable for Buyer's process and application. Seller's statements, engineering and technical information, and recommendations are provided for the Buyer's convenience and the accuracy or completeness thereof is not warranted. If, after Seller receives written notice, within the warranty period, that any goods allegedly do not meet Seller's warranty, and Seller, in its sole discretion, determines that such claim is valid, Seller's sole obligation and Buyer's exclusive remedy for breach of the foregoing warranty or any Seller published warranty, will be, at Seller's option, either: (i) repair or replacement of such goods or (ii) credit or refund to Buyer for the purchase price from Seller. In the case of repair or replacement, Seller will be responsible for the cost of shipping the parts but not for labor to remove, repair, replace or reinstall the allegedly defective goods. Refurbished goods may be used to repair or replace the goods and the warranty on such repaired or replaced goods shall be the balance of the warranty remaining on the goods which were repaired or replaced. Any repair or rework made by anyone other than Seller is not permitted without prior written authorization by Seller, and voids the warranty set forth herein. Seller warrants to Buyer that it will perform services in accordance with the Sales Documents using personnel of required skill, experience and qualifications and in a professional and workmanlike manner in accordance with generally recognized industry standards for similar services. With respect to any services subject to a claim under the warranty set forth above, Seller shall, in its sole discretion, (i) repair or re-perform the applicable services or (ii) credit or refund the price of such services at the pro rata contract rate and such shall be Seller's sole obligation and the exclusive remedy for breach of the foregoing warranty on services. Products manufactured by a third party ("Third Party Product") may constitute, contain, be contained in, incorporated into, attached to or packaged together with, the goods. Buyer agrees that: (a) Third Party Products are excluded from Seller's warranty in this Section 7 and carry only the warranty extended by the original manufacturer, and (b) Seller's liability in all cases is limited to goods of Seller's design and manufacture only. EXCEPT FOR SELLER'S WARRANTY OF TITLE TO THE GOODS, SELLER EXPRESSLY DISCLAIMS AND EXCLUDES ALL OTHER WARRANTIES WHATSOEVER, WHETHER, EXPRESSED OR IMPLIED, ORAL, STATUTORY, OR OTHERWISE, INCLUDING BUT NOT LIMITED TO MERCHANTABILITY, FITNESS FOR A PARTICULAR PURPOSE, NON-INFRINGEMENT OF THIRD PARTY INTELLECTUAL PROPERTY AND ANY WARRANTIES ARISING FROM TECHNICAL ADVICE OR RECOMMENDATIONS, COURSE OF DEALING OR OF PERFORMANCE, CUSTOM OR USAGE OF TRADE. Seller's obligations do not cover normal wear and tear or deterioration, defects in or damage to any goods resulting from improper installation, accident or any utilization, maintenance, repair or modification of the goods, or any use that is inconsistent with Seller's instructions as to the storage, installation, commissioning or use of the goods or the designed capabilities of the goods or that, in its sole judgment, the performance or reliability thereof is adversely affected thereby, or which is subjected to abuse, mishandling, misuse or neglect or any damage caused by connections, interfacing or use in unforeseen or unintended environments or any other cause not the sole fault of Seller, and shall be at Buyer's expense. Seller's warranty is contingent upon the accuracy of all information provided by Buyer. Any changes to or inaccuracies in any information or data provided by Buyer voids this warranty. Seller does not warrant that the operation of the goods will be uninterrupted or error-free, that the functions of the goods will meet Buyer's or its customer's requirements unless specifically agreed to, or that the goods will operate in combination with other products selected by Buyer or Buyer's customer for its use.

The terms of this warranty may only be modified by a special warranty document signed by a Director, General Manager or Vice President of Donaldson. To ensure proper operational performance of your equipment, use only genuine Donaldson replacement parts.

This Product is provided subject to and conditioned upon Donaldson's Terms of Sale ("Terms"), a current copy of which is located at termsofsale.donaldson.com. These Terms are incorporated herein by reference. By purchasing or using this Product, the user accepts these Terms. The Terms are available on our website or by calling our customer service line at 1-800-365-1331.

Significantly improve the performance of your collector with genuine Donaldson Torit replacement filters and parts. **Call Donaldson Torit at 800-365-1331.**

Important Notice: Many factors beyond the control of Donaldson can affect the use and performance of Donaldson products in a particular application, including the conditions under which the product is used. Since these factors are uniquely within the user's knowledge and control, it is essential the user evaluate the products to determine whether the product is fit for the particular purpose and suitable for the user's application. All products, product specifications, availability and data are subject to change without notice, and may vary by region or country.



Donaldson Company, Inc.
Minneapolis, MN
donaldsontorit.com • shop.donaldson.com

North America
Email: donaldsontorit@donaldson.com
Phone: (USA): +1-800-365-1331 • (MX): +1-800-343-3639

Australasia
Email: marketing.australia@donaldson.com
Phone: +61-2-4350-2000
Toll Free: (AU) +1800-345-837 • (NZ) +0800-743-387

China
Email: info.cn@donaldson.com
Phone: +86-400-820-1038

Donaldson Europe B.V.B.A.
Email: IAF-europe@donaldson.com
Phone: +32-16-38-3811

India
Email: info.dfis@donaldson.com
Phone: +91-124-4807-400 • +1-800-103-5018

Japan
Email: jp-ndl.ifswweb@donaldson.com
Phone: +81-42-540-4112

Korea
Email: iaf-kr@donaldson.com
Phone: +82-2-517-3333

Latinoamerica
Email: IndustrialAir@donaldson.com
Phone: +52-449-300-2442

South Africa
Email: SAMarketing@donaldson.com
Phone: +27 11 997 6000

Southeast Asia
Email: IAF.SEA@donaldson.com
Phone: (65) 63117373

IOM AG8732701(ENG), Revision 0 (April 2022) ©2022 Donaldson Company, Inc. Donaldson, Torit and the color blue are marks of Donaldson Company, Inc. All other marks belong to their respective owners.